

Niedervoltnetzteil

von Chassis K12 L64 V64 P V32 G32 L +12 12,5V Analogfunk-Ausgabe TRD-Grundplatte

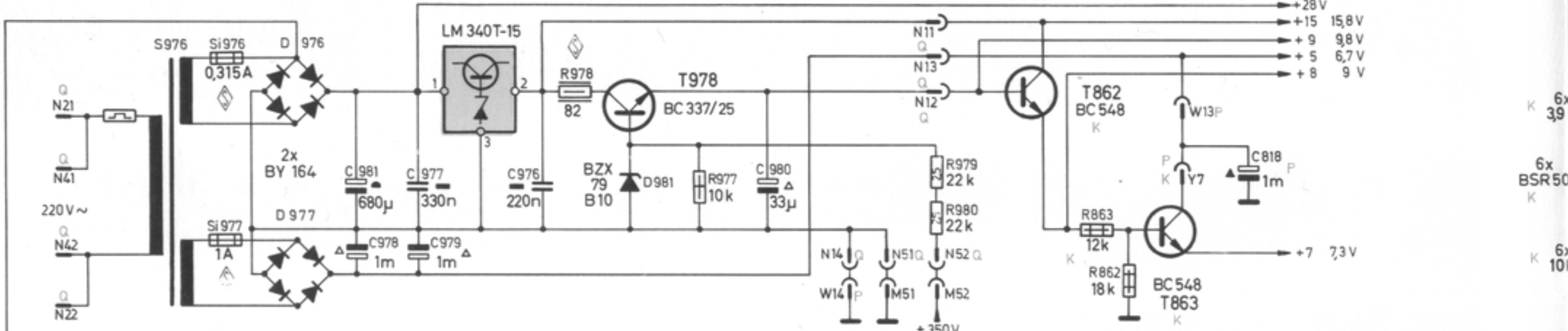

2

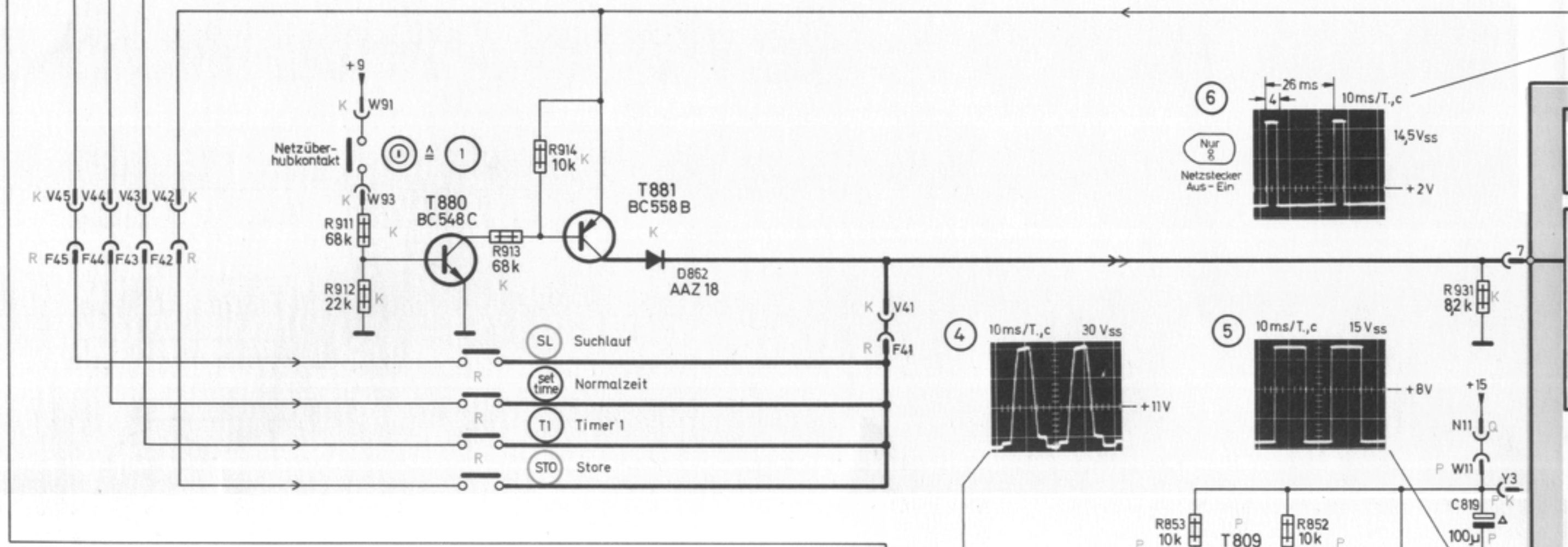

1

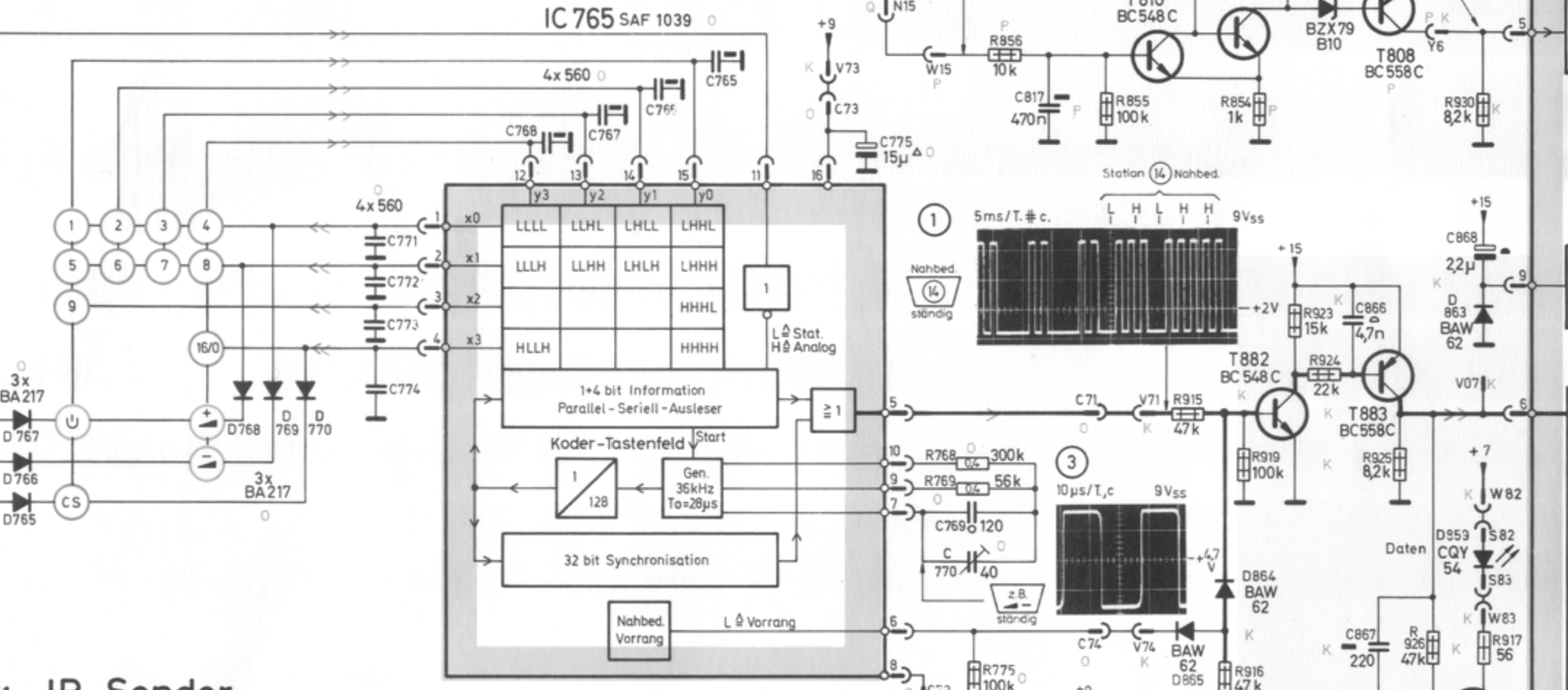

U951 IR-Sender

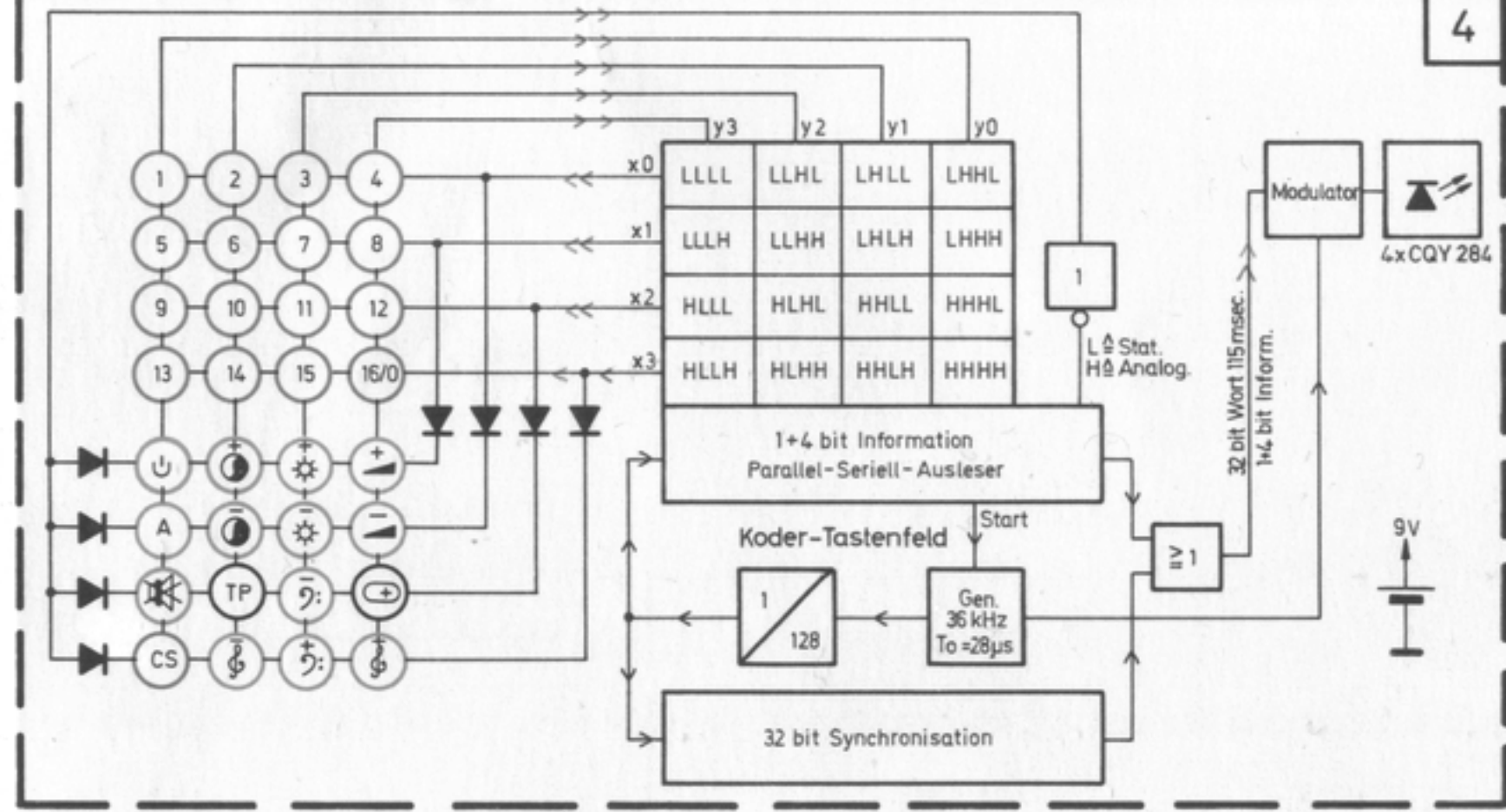

U952 IR-Empfäng.

